

分割定位柱·有六角環和鎖固

EH 22120.



產品描述

索引柱塞用於索引鑽孔。

材質

本體

- 切削鋼， 染黑
- 不鏽鋼 1.4305

固定梢子

- 鋼， 硬化
- 不銹鋼 1.4305， 鍍鎳

手把

- 塑膠(PA6)， 黑色， 無光澤的

組裝

螺絲長度可由分割定位柱襯套調整 (EH 22120.)。

操作

旋鈕被拉出， 轉90度並由一個槽口夾住 (此時鎖銷不應突出)。

更多資訊

注意事項

不可移動的旋鈕。
螺帽必須個別購買。

更多產品

- 支持座, 用於分割螺栓和分割定位柱, 壓鑄
- 定位襯套, 適用於分割螺栓和分割定位柱
- 距離調整環, 適用於分割定位柱

圖面

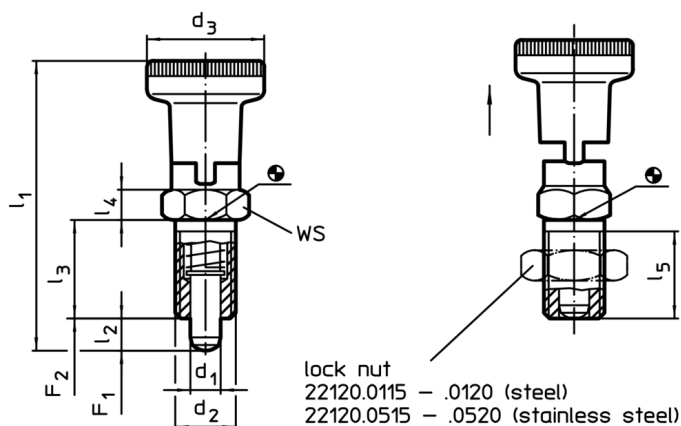

訂單資訊

d ₁	d ₂	d ₃	尺寸					WS	彈簧荷重 ¹⁾		溫度		RoHS	REACH	品號	
			l ₁	l ₂ min	l ₃	l ₄	l ₅ min		F ₁	F ₂	min	max.				[g]
-0,02 -0,04			[mm]					[mm]	[N]		[°C]					
5	M10 x 1	21	51,0	5	17	5	15	12	6,0	14	-30	80	22	RoHS 認證	contains no SVHC materials	22120.0205
6	M12 x 1,5	25	61,0	6	20	6	17	14	6,5	19	-30	80	36	RoHS 認證	contains no SVHC materials	22120.0206
8	M16 x 1,5	31	75,5	7	26	8	23	19	11,5	28	-30	80	79	RoHS 認證	contains no SVHC materials	22120.0208
10	M20 x 1,5	31	91,0	10	33	10	30	22	28,0	54	-30	80	134	RoHS 認證	contains no SVHC materials	22120.0210

¹⁾ 統計平均值

d ₁ -0,02 -0,04	d ₂	d ₃	尺寸					WS [mm]	彈簧荷重 ¹⁾		溫度		RoHS	REACH	品號	
			l ₁ ~ [mm]	l ₂ min	l ₃	l ₄	l ₅ min		F ₁ ~ [N]	F ₂ ~ [N]	min [°C]	max. [°C]				
不銹鋼																
5	M10 x 1	21	51,0	5	17	5	15	12	6,0	14	-30	80	22	RoHS 認證	contains no SVHC materials	22120.0605
6	M12 x 1,5	25	61,0	6	20	6	17	14	6,5	19	-30	80	36	RoHS 認證	contains no SVHC materials	22120.0606
8	M16 x 1,5	31	75,5	7	26	8	23	19	11,5	28	-30	80	79	RoHS 認證	contains no SVHC materials	22120.0608
10	M20 x 1,5	31	91,0	10	33	10	30	22	28,0	54	-30	80	134	RoHS 認證	contains no SVHC materials	22120.0610

¹⁾ 統計平均值

配件

	尺寸 d ₂ [mm]	扳手尺寸 [mm]	重量 [g]	RoHS	REACH	品號
鎖緊螺帽 ISO 8675(DIN 439) 適用於下列尺寸, 鋼						
	M10 x 1	16	5,2	RoHS 認證	contains no SVHC materials	22120.0115
	M12 x 1,5	18	7,4	RoHS 認證	contains no SVHC materials	22120.0116
	M16 x 1,5	24	18,0	RoHS 認證	contains no SVHC materials	22120.0118
	M20 x 1,5	30	32,0	RoHS 認證	contains no SVHC materials	22120.0120
鎖緊螺帽 ISO 8675(DIN 439) 適用於下列尺寸, 不銹鋼						
	M10 x 1	16	5,2	RoHS 認證	contains no SVHC materials	22120.0515
	M12 x 1,5	18	7,4	RoHS 認證	contains no SVHC materials	22120.0516
	M16 x 1,5	24	18,0	RoHS 認證	contains no SVHC materials	22120.0518
	M20 x 1,5	30	32,0	RoHS 認證	contains no SVHC materials	22120.0520

應用範例

